

Impressed Current Laboratory Testing of Aluminum and Zinc Alloy Anodes

This NACE International standard represents a consensus of those individual members who have reviewed this document, its scope, and provisions. Its acceptance does not in any respect preclude anyone, whether he or she has adopted the standard or not, from manufacturing, marketing, purchasing, or using products, processes, or procedures not in conformance with this standard. Nothing contained in this NACE standard is to be construed as granting any right, by implication or otherwise, to manufacture, sell, or use in connection with any method, apparatus, or product covered by letters patent, or as indemnifying or protecting anyone against liability for infringement of letters patent. This standard represents minimum requirements and should in no way be interpreted as a restriction on the use of better procedures or materials. Neither is this standard intended to apply in all cases relating to the subject. Unpredictable circumstances may negate the usefulness of this standard in specific instances. NACE assumes no responsibility for the interpretation or use of this standard by other parties and accepts responsibility for only those official NACE interpretations issued by NACE in accordance with its governing procedures and policies which preclude the issuance of interpretations by individual volunteers.

Users of this NACE standard are responsible for reviewing appropriate health, safety, environmental, and regulatory documents and for determining their applicability in relation to this standard prior to its use. This NACE standard may not necessarily address all potential health and safety problems or environmental hazards associated with the use of materials, equipment, and/or operations detailed or referred to within this standard. Users of this NACE standard are also responsible for establishing appropriate health, safety, and environmental protection practices, in consultation with appropriate regulatory authorities if necessary, to achieve compliance with any existing applicable regulatory requirements prior to the use of this standard.

CAUTIONARY NOTICE: NACE standards are subject to periodic review, and may be revised or withdrawn at any time in accordance with NACE technical committee procedures. NACE requires that action be taken to reaffirm, revise, or withdraw this standard no later than five years from the date of initial publication and subsequently from the date of each reaffirmation or revision. The user is cautioned to obtain the latest edition. Purchasers of NACE standards may receive current information on all standards and other NACE publications by contacting the NACE FirstService Department, 15835 Park Ten Place, Houston, TX 77084-5145 (telephone +1 281-228-6200).

ABSTRACT

Describes a quality assurance procedure for determining the potential and current capacity characteristics under laboratory conditions for aluminum and zinc alloy anodes used for cathodic protection. The procedure screens various heats or lots of anodes to determine performance consistency on a regular basis from lot to lot. One method for anode potential evaluation and two methods (mass loss and hydrogen evolution) for current capacity evaluations are described. Performance criteria and sampling frequency are left to the discretion of users of the standard.

KEYWORDS

anodes, cathodic protection, testing.

Foreword

*In NACE standards, the terms **shall**, **must**, **should**, and **may** are used in accordance with the definitions of these terms in the NACE Publications Style Manual. The terms **shall** and **must** are used to state a requirement, and are considered mandatory. The term **should** is used to state something good and is recommended, but is not considered mandatory. The term **may** is used to state something considered optional.*

This standard test method describes a quality assurance procedure for determining the potential and current capacity characteristics under laboratory conditions for aluminum and zinc alloy anodes used for cathodic protection (CP). Field performance of anodes should be evaluated to correspond to actual anode performance.

This standard is intended primarily for users, designers, and manufacturers involved with the application of CP in marine environments. This standard can be used by manufacturers and users of aluminum and zinc anodes for quality control verification. The most common usage is expected to be by manufacturers to meet quality control requirements requested by the purchasing user. This standard is based on experiences from the paper by J.F. Brown Jr., "Quality Control Testing of Aluminum Anodes: T-7L-2 Task Group Progress Report,"¹ and on ANSI/NACE SP01 15/ISO 15589-2² and Military Specification MIL-DTL-18001.³

This standard was originally prepared in 1990 by NACE International Task Group T-7L-2 on Aluminum Anode Quality Control, a component of Unit Committee T-7L on Cathodic Protection, in conjunction with ASTM⁽¹⁾ Task Group G01-09-02 T-1. It was revised by Task Group T-7L-12 in 1998, reaffirmed by Specific Technology Group (STG) 30, "Oil and Gas Production: Cathodic Protection," in 2006, and revised in 2012 by Task Group (TG) 459, "Review and Revise as Necessary NACE Standard TM0190-2006." It was reaffirmed by STG 30 in 2017. It is issued by NACE under the auspices of STG 30. These committees are composed of industry representatives, including producers, consumers, and interested individuals.

⁽¹⁾ASTM International (ASTM), 100 Barr Harbor Dr., West Conshohocken, PA 19428-2959.

Impressed Current Laboratory Testing of Aluminum and Zinc Alloy Anodes

1.	General	4
2.	Summary of Test Method	5
3.	Test Environment	5
4.	Test Conditions.....	8
5.	Test Specimens.....	9
6.	Test Equipment	9
7.	Test Procedure	10
8.	Reporting of Test Results	12
	References.....	13
	Bibliography	13

Figures

Figure 1: Hydrogen Evolution Test Set-Up	6
Figure 2: Alternate Test Cell Set-Up (Without Hydrogen Evolution Test).....	7
Figure 3: Sacrificial Copper Plate and Copper Coulometer.....	7
Figure 4: Wiring Diagram.....	8

Tables

Table 1: Nominal Alloy Composition Ranges for Anodes Tested (%)	4
Table 2: Range of Evaluation Results.....	4

Section 1: General

- 1.1** This standard test method describes a laboratory procedure for determining the potential and current capacity characteristics of aluminum and zinc alloy anodes used for CP. It provides a means for screening various heats or lots of anodes to determine performance consistency on a regular basis from lot to lot. Items such as sampling frequency and performance criteria (i.e., test values and intermediate times) are left to the discretion of the user of the test method.
- 1.2** One test method for anode potential evaluation and two test methods for anode current capacity evaluations are described.
- 1.3** The actual values obtained in these tests should not be used for design purposes because they represent laboratory testing.
- 1.4** This procedure can be validated by using zinc anode samples as a reference in the test to verify results of aluminum anodes tested. Zinc samples shall be as defined in ASTM B418⁴ or Military Specification MIL-DTL-18001 for zinc anodes.
- 1.5** This procedure was evaluated by testing alloys of Al-Zn-Sn, Al-Zn-Hg, Al-Zn-In-Mg, and MIL-DTL-18001 zinc of the respective nominal alloy composition ranges shown in Table 1. The results of the test are reported in Paper No. 346 presented at CORROSION/84.¹
- 1.6** The precision of the test has not been validated. The scatter in the test results is considered to result from heterogeneities in aluminum alloy anode materials in general, as tested, rather than the test method itself. Only anode materials exhibiting good, reproducible performance (in accordance with this test method) and meeting manufacturer or user specifications are acceptable.

1.6.1 Ranges of performance from those alloys tested are listed in Table 2.

Table 1
Nominal Alloy Composition Ranges for Anodes Tested (%)

	Al-Zn-Sn	Al-Zn-Hg	Al-Zn-In-Mg	Zinc (MIL-DTL-18001)
Zn	6.0 to 8.0	1.25 to 2.00	1.0 to 3.0	Remainder
Sn	0.10 to 0.20	—	—	—
Si	—	—	—	0.125 max.
Hg	—	0.030 to 0.08	—	—
Pb	—	—	—	0.006 max.
Mg	—	—	0.50 to 1.0	—
In	—	—	0.20	—
Fe	0.10 max.	0.10 max.	0.10 max.	0.005 max.
Cd	—	—	—	0.025 to 0.15
Cu	0.003 max.	0.003 max.	0.010 max.	0.005 max.
Al	Remainder	Remainder	Remainder	0.10 to 0.50

Table 2
Range of Evaluation Results

Alloy	Operating Potential (SCE ^(A) -mV)	Hydrogen Evolution (% Efficiency)	Impressed Current Capacity	
			A-h/kg	A-h/lb
Al-Zn-Sn	940 to 1,176	70 to 94	1,014 to 2,711	460 to 1,230
Al-Zn-Hg	830 to 1,114	96	2,623 to 2,949	1,190 to 1,338
Al-Zn-In-Mg	1,032 to 1,140	90	2,354 to 2,742	1,068 to 1,244
Zinc	969 to 1,051	98	754 to 804	342 to 365

^(A) Saturated calomel electrode.

1.6.2 Al/Zn/In alloys have been found suitable for this test method (see ANSI/NACE SP0115/ISO 15589-2 and Military Specification MIL-DTL-24779).⁵

Section 2: Summary of Test Method

- 2.1 A 16,000 mm³ (1.0 in³) sample of alloy anode material shall be immersed in synthetic seawater (see ASTM D1141⁶) at ambient temperature for two weeks (336 h), while anodically polarized at an impressed current density value of 6.2 A/m² (4.0 mA/in²). Potentials shall be measured periodically and current capacity determined by the method(s) described in Paragraph 2.4.
- 2.2 The test shall be conducted with the synthetic seawater electrolyte at room temperature of 23 ± 3 °C (73 ± 5 °F), or other temperature specified by the client, and shall be recorded each time potential measurements are made.
- 2.3 Anode potentials shall be measured with a standard reference electrode, such as an SCE, at 3 h, 24 h, 48 h, 72 h, and 336 h. Potentials may be taken more frequently if desired.
- 2.3.1 For tests conducted at temperatures other than room temperature, consideration should be given to the impact of the test temperature on the potential measurement.
- 2.4 Anode current capacity shall be determined by the Mass Loss Method. This method may be supplemented by the Hydrogen Evolution Method.
- 2.4.1 Mass Loss Method: The total current passed through the system shall be measured by a coulometer. Anode mass loss shall be determined at the end of the two-week test when the samples are removed, cleaned, and weighed. Mass loss current capacities shall be determined from knowledge of the total charge passed through the system and the mass loss of the anode samples.
- 2.4.2 Hydrogen Evolution Method: Hydrogen that evolved from the anode as a result of local cell action under impressed conditions shall be collected in a graduated buret after 72 h of testing, and the anode efficiency shall be calculated. The volume of gas collected during the collection time, the elapsed time, and the current flow through the anode samples shall be used for hydrogen evolution efficiency calculations.
- 2.4.3 For tests conducted at temperatures other than room temperature, consideration should be given to the impact of the test temperature on the current capacity values.
- 2.5 The causes of noble (more positive) potential results or low current capacity, or both, measured on a particular lot of anodes relative to established benchmarks for a particular alloy, should be investigated.
- 2.6 Zinc anode samples conforming to ASTM B418 should be used in the test as a reference material. Instructions for cleaning zinc samples before testing are given in ASTM G1.7

Section 3: Test Apparatus

- 3.1 Anode Test Cell: The container (1.5 L [0.40 gal]), shown in Figure 1 with a titanium sample support rod, steel screen cathode, and gas buret for hydrogen collection, shall be filled with synthetic seawater to a level 13 mm (0.50 in) from the top. A minimum distance of 19 mm (0.75 in) between the anode sample and the cathode screen should be maintained.

3.1.1 If the steel cathode is galvanized, the coating shall be removed from the screen prior to the first test. This may be accomplished by immersing the screen in 10% nitric acid ($[HNO_3]$, [90 parts water, 10 parts nitric acid by volume]) at 49 to 66 °C (120 to 150 °F) until the coating is removed. The screen should be rinsed in reagent water (see ASTM D1193)⁸ to remove the acid. The nitric acid solution shall be handled with care.

3.1.2 A stainless steel beaker or carbon steel container may be used as a cathode, or a plastic test cell with stainless steel or carbon steel mesh cathode may be used as shown in Figure 2.

3.2 Copper Coulometer: The coulometer (such as the type shown in Figure 3) shall be filled with copper coulometer solution as described in Paragraph 4.3. Copper plates shall be a minimum of 99.9% purity.

3.2.1 An electronic coulometer of sufficient precision ($\pm 1\%$) may be substituted for the copper coulometer.

3.3 Power Supply: A constant-current direct current (DC) power supply should be used in conjunction with the DC milliammeter, as shown in Figure 4. The DC impressed current required in this test shall be 24 ± 0.2 mA.

3.3.1 A voltage-regulated DC power supply capable of regulation at 24 mA with a 1% deviation of full-scale adjustment may be substituted for the constant current supply.

3.4 Any number of anode samples may be tested at one time by wiring multiple test cells in series in the circuit, as shown in Figure 4, provided that the power supply is capable of supplying sufficient voltage to maintain the impressed current at 24 ± 0.2 mA through each test cell.

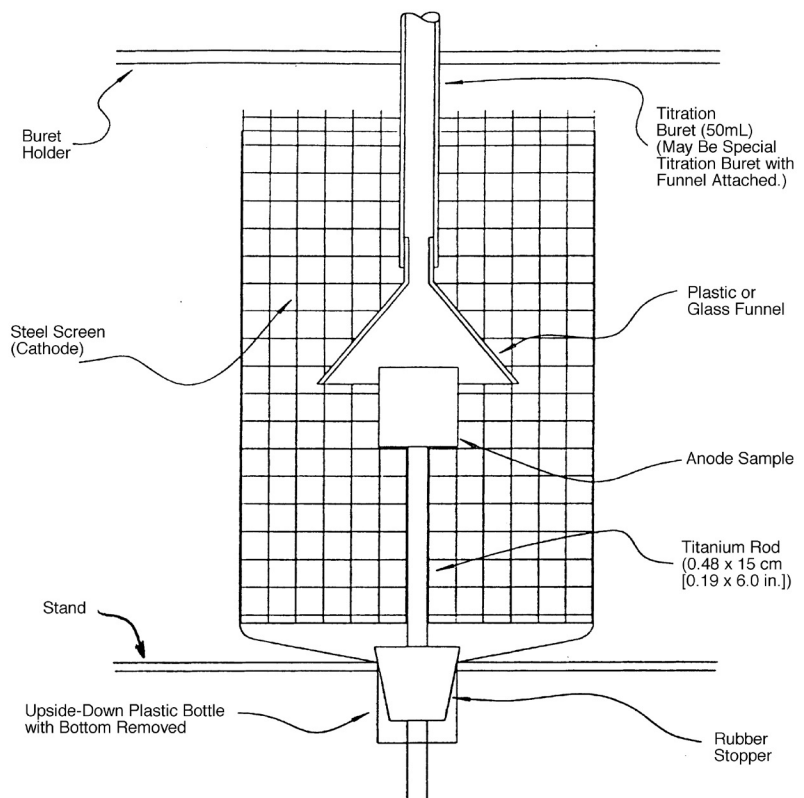

Figure 1: Hydrogen Evolution Test Set-Up

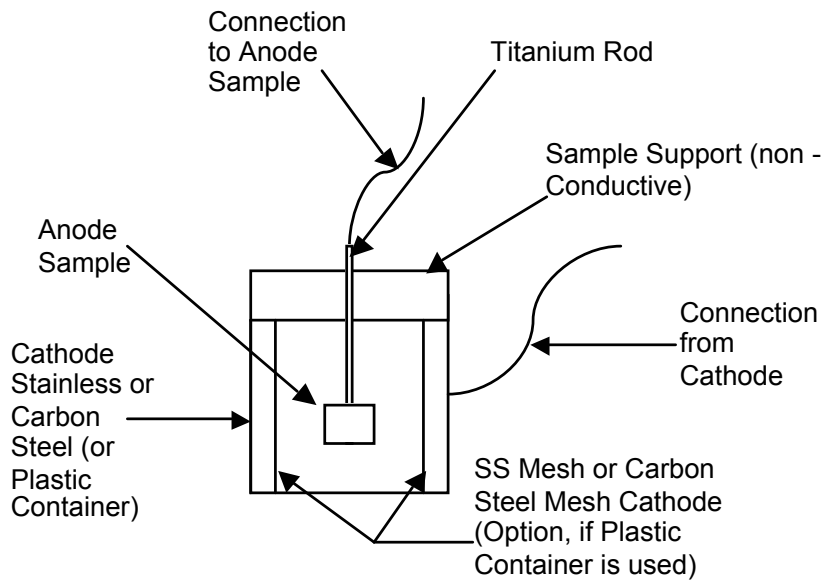

Figure 2: Alternate Test Cell Set-Up (Without Hydrogen Evolution Test)

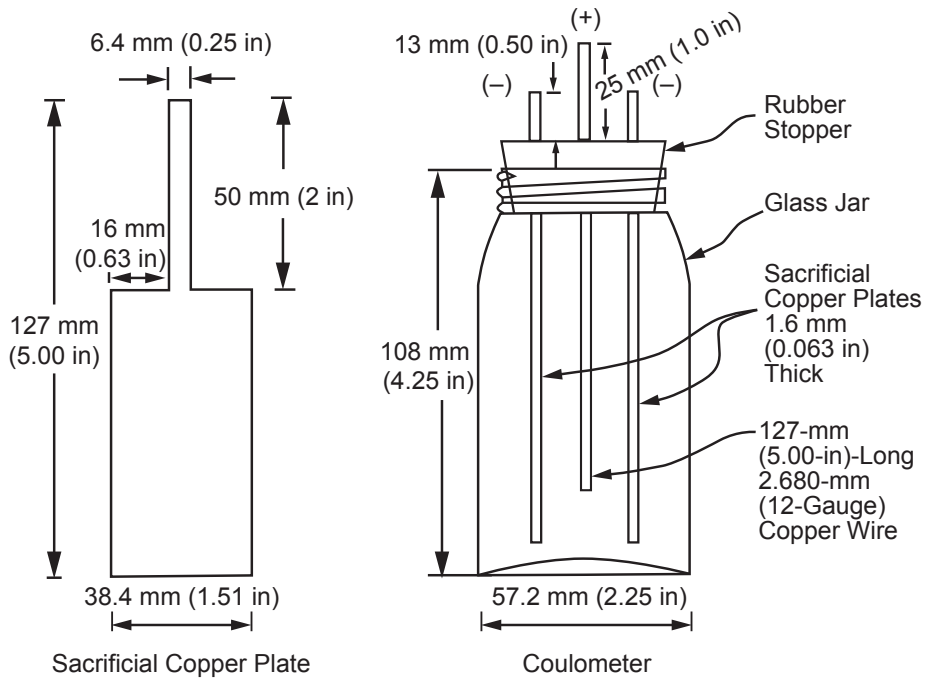

Figure 3: Sacrificial Copper Plate and Copper Coulometer

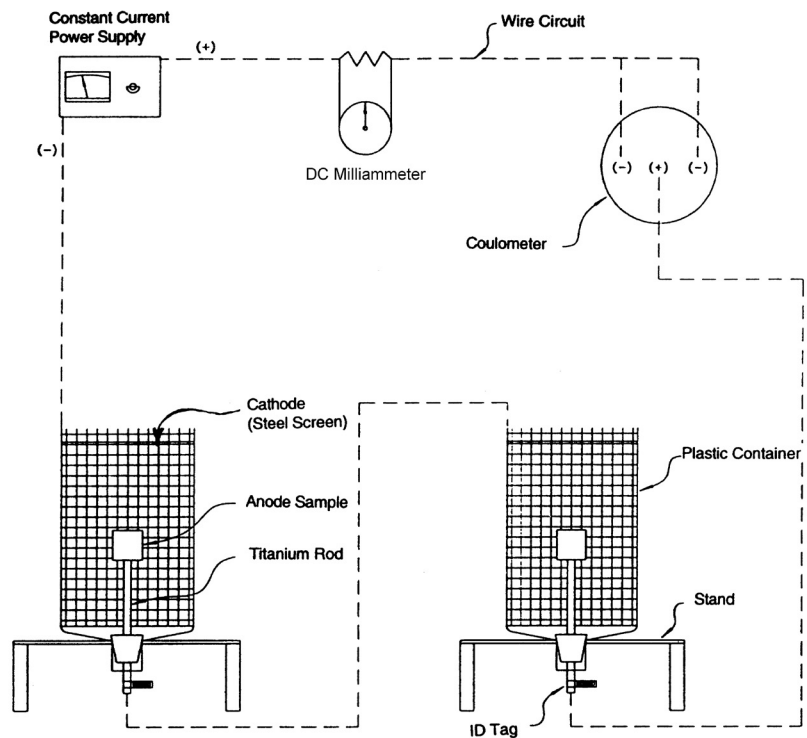

Figure 4: Wiring Diagram

Section 4: Reagents

- 4.1 Anode Pre-cleaning Solution: 50 g of sodium hydroxide (NaOH) shall be dissolved in 1 L of reagent water.
- 4.2 Synthetic Seawater Electrolyte: The electrolyte shall be prepared in accordance with ASTM D1141. The addition of trace heavy metals is not required. Sufficient electrolyte should be made in a single batch prior to each test.
- 4.3 Copper Coulometer Solution shall be prepared as follows:
- 100 g reagent grade hydrated copper sulfate ($\text{CuSO}_4 \cdot 5\text{H}_2\text{O}$)
 - 27 mL reagent grade sulfuric acid (H_2SO_4)
 - 62 mL reagent grade 95% ethanol
 - 1 L reagent water
- 4.4 Anode Post-cleaning Solution shall be prepared as one of the following:
- 4.4.1 Chromic acid solution:
- 28 g chromium trioxide (CrO_3), reagent grade
 - 57.4 mL phosphoric acid (H_3PO_4), 85% strength reagent grade
 - 1,400 mL water, reagent grade
- 4.4.2 Concentrated nitric acid (HNO_3) may be substituted for the chromic acid solution.
- 4.5 CAUTION: The chemicals used as cleaning reagents are hazardous, and proper precautions shall be observed in their handling and mixing. Rubber gloves and eye protection shall be worn when handling the acid and base solutions used in precleaning and postcleaning fluids and coulometer electrolyte. Precautions must be taken to avoid breathing dust from CrO_3 or fumes from post-cleaning solutions.

Section 5: Preparation of Test Specimens

The following procedure shall be used to prepare test specimens:

- 5.1 Cut a 16,000 mm³ (1.0 in³) sample from each anode to be tested. Individual test samples, with equivalent 3,900 mm² (6.0 in²) surface area, may be cast in sample molds. The sample should be marked with a suitable identification number stamped in the surface. Cast surfaces may be included in the sample when the sample is removed from the anode or the sample mold.
- 5.2 Drill a hole 13 mm (0.50 in) deep in the center of one face of the cube using a No. 25 drill bit and thread with a 10–24 tap.⁽²⁾
- 5.3 Dip each tapped sample in the anode pre-cleaning solution for 5 min at 82 ± 6 °C (180 ± 10 °F). Rinse in reagent water.
 - 5.3.1 Briefly dip the sample in concentrated nitric acid (HNO₃) to remove black residue (smut) from the surface. Rinse thoroughly first with reagent water, then with acetone, and oven dry at 121 ± 11 °C (250 ± 20 °F) for 15 min.
- 5.4 Allow the sample to cool in a low-humidity environment (such as a desiccator), and weigh to the nearest 0.1 mg on an analytical balance.
- 5.5 If required, after the samples are weighed, mask excess surface area with a coating that can be readily removed following the test.

Section 6: Preparation of Apparatus for Test

- 6.1 The matching threads on the titanium support rods should be wire-brush cleaned and tightly secured in the threaded hole in the sample. The rod should be pushed through the hole in the rubber stopper so that approximately 25 mm (1.0 in) protrudes beyond the end of the stopper.
 - 6.1.1 Because the stamped sample identification numbers on each anode sample may be obliterated by corrosion, a small flag of tape with the corresponding number should be attached to the end of the support rod to maintain sample identification throughout the test and subsequent cleaning procedures.
- 6.2 The test cell should be prepared by inserting the stoppers, with anodes attached, into the plastic containers and inserting the cathode screens as shown in Figures 1 and 2. The cells should be secured to the test stand support.
 - 6.2.1 For the mass loss method (without hydrogen evolution test), the sample may be inserted from the top or the bottom of the test cell.
- 6.3 If a copper coulometer is used, the following procedure shall be followed:
 - 6.3.1 Cut a 127 ± 13 mm (5.00 ± 0.50 in) piece of 2.680 mm (12 gauge), unvarnished pure copper wire, and clean it lightly with 600 grit sandpaper. Rinse the wire in acetone and dry in a 121 ± 11 °C (250 ± 20 °F) oven for 15 min. Allow the wire to cool in a low-humidity environment (such as a desiccator), and then weigh it to the nearest 0.1 mg on an analytical balance.
 - 6.3.2 Prepare sacrificial, unvarnished pure copper plates in the same manner. These plates do not need to be weighed.

⁽²⁾Drill bit No. 25 and 10-24 tap are U.S. standards for preparing a threaded hole for a standard 10-24 screw, which is 4.826 mm in diameter. The closest metric equivalent is an ISO M5 screw (5 mm in diameter) with appropriate tap and starter drill bit size.

- 6.3.3** Insert the weighed copper wire and the sacrificial copper plates into the rubber stopper as shown in Figure 3.
- 6.4** The test cells, power supply, and copper coulometer (or electronic current integrator) shall be connected in series as shown in Figure 4. The correct polarity shall be observed with reference to the power supply.

Section 7: Procedure

- 7.1** The bulk synthetic seawater shall be mixed for a minimum of 24 h prior to the beginning of the test (e.g., bubble air, stir bar, or paddle) to mix the electrolyte solution completely.
- 7.2** The test cells shall be filled with aerated seawater to within 13 mm (0.50 in) of the top of the containers.
- 7.3** The coulometer shall be filled with copper coulometer solution to within 13 mm (0.50 in) of the bottom of the rubber stopper.
- 7.4** The power supply shall be turned on and the voltage and resistance adjusted to give a current of 24 ± 0.2 mA as measured by the milliammeter. This provides a nominal current density of 6.2 A/m^2 (4.0 mA/in^2) for $3,870 \text{ mm}^2$ (6.00 in^2) samples.
- 7.4.1** The current should be checked periodically for drift throughout the test and adjusted to 24 ± 0.2 mA, as required.
- 7.5** Anode operating potential measurements taken with a standard reference electrode, such as an SCE, after 3 h, 24 h, 48 h, 72 h, 336 h, and as desired, shall be made with the current flowing. The potentials and the temperature of the seawater electrolyte shall be recorded.
- 7.5.1** The fiber junction tip of an SCE or Luggin probe shall be placed within 1 mm (0.04 in) of the anode surface. The potential between the reference and the anode surface shall be measured with a digital high-impedance (106 ohms or greater) DC millivoltmeter (positive lead attached to anode support rod and negative lead to the SCE). With an analog (also high-impedance) voltmeter, the connections shall be reversed to obtain an on-scale reading (unless the meter is either the center-zero type or has a polarity-reversing switch). (A Luggin probe is a glass tube with a fine opening in one end and a larger opening in the other end, into which the reference electrode is inserted. A bentonite plug at the fine end and electrolyte from the test cell contained in the tube form a salt bridge or electrolytic connection between the reference electrode and the anode). The polarity, \pm , of the measured potential shall be recorded in all cases.
- 7.6** Hydrogen evolution measurements shall be started after at least 72 h have elapsed in the test.
- 7.6.1** The funnel end of a 50 mL buret shall be submerged into the test cell and secured as shown in Figure 1. The funnel should be about 6.4 mm (0.25 in) from the cube surface.
- 7.6.2** The buret should be filled by suction, and the liquid level shall be adjusted and recorded. The buret stopcock shall be closed and the time recorded. Burets should be checked for air leakage through the stopcock prior to use.
- 7.6.3** Hydrogen gas shall be collected in the buret for 24 h.

7.6.3.1 The rate of hydrogen evolution depends on the efficiency of the anode. If, for any sample, the amount of hydrogen collected at the end of the first eight hours indicates buret capacity is likely to be exceeded, the gas collection should then be terminated for that sample. This collection time shall be recorded for use in subsequent calculations.

7.6.4 For each sample, the volume of the hydrogen collected and the collection duration shall be recorded. The burets should be removed after the hydrogen collection is completed.

7.7 In order to maintain pH stability, the seawater shall be changed every four or five days (i.e., twice during the two-week test). The fresh electrolyte shall be aerated for 24 h prior to the solution change, as noted in Paragraph 7.1.

7.8 After the test has run for 336 h (two weeks), the circuit shall be interrupted and the samples removed for cleaning. The seawater shall be disposed of properly.

7.9 The cathode (center) wire shall be removed from the copper coulometer, rinsed in reagent water, and dried for 15 min at 121 ± 11 °C (250 ± 20 °F). The wire shall be allowed to cool in a low-humidity environment (such as a desiccator) and weighed to the nearest 0.1 mg on an analytical balance.

7.9.1 If an electronic current integrator is used, the total charge passed during the test shall be recorded at termination.

7.10 If excess surface area was masked (Paragraph 5.5), the coating should be completely removed at this time.

7.11 In order to remove all corrosion products, the anode samples shall be thoroughly cleaned by immersion in the anode post cleaning solution for 10 min at 82 ± 6 °C (180 ± 10 °F). The samples may be suspended in the cleaning solution using a stainless steel screw inserted in the anode to obtain uniform cleaning.

7.11.1 Cleaned samples shall be rinsed thoroughly with reagent water and dried. The screw shall be removed to rinse the tapped hole. The samples shall be dried in a 121 ± 11 °C (250 ± 20 °F) oven for 15 min, then cooled in a low-humidity environment (such as a desiccator) and weighed to the nearest 0.1 mg on an analytical balance.

7.11.2 CAUTION: The cleaning operation shall be conducted under a fume hood, and rubber gloves and eye protection shall be worn. Regulations may govern the discharge of hexavalent chromium into sewer discharge systems; therefore, spent cleaning solution and rinse water shall be disposed of properly.

7.11.2.1 Cr (VI) waste can be reduced to Cr (III) by dissolving 3.75 g of sodium bisulfite (NaHSO_3) per g of Cr (VI) in the waste solution and mixing for 12 h.

Section 8: Calculation of Efficiency

- 8.1 Mass Loss Method. Anode current capacity shall be calculated for each sample as shown in Equation (1) or (2):

$$\text{Current Capacity (ampere} \cdot \text{hours/kilogram)} = \frac{C}{W} \times 1,000 \quad (1)$$

$$\text{Current Capacity (ampere} \cdot \text{hours/pound)} = \frac{C}{W} \times 453.6 \quad (2)$$

where:

C = Total charge passed in two-week (336 h) test (ampere · hours) (see Paragraph 8.1.1)

W = Mass loss of anode samples (grams)

- 8.1.1 For a copper coulometer, C in Equations (1) and (2) above shall be as shown in Equation (3):

$$C = 0.8433 W_{cu} \quad (3)$$

where:

W_{cu} = mass increase of copper cathode wire at end of test (grams).

- 8.1.2 Anode % Efficiency Calculation Based on Theoretical Current Capacity of Pure Aluminum and Pure Zinc.

Aluminum Theoretical Current Capacity = 2,981 A·h/kg (1,352 A·h/lb).

Zinc Theoretical Current Capacity = 780 A·h/kg (354 A·h/lb)

Anode % Efficiency = (Obtained Current Capacity x 100) / Theoretical Current Capacity).

- 8.2 Hydrogen Evolution Method:

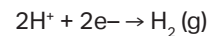

Anode efficiency calculation shall be as shown in Equation (4):

$$\text{Anode Efficiency (\%)} = \frac{I \times 100}{I + \frac{132V}{t}} \quad (4)$$

where:

I = Impressed current in mA (e.g., 24 mA)

V = Volume of hydrogen evolved in time t (mL)

t = Elapsed time of hydrogen collection (minutes)

- 8.2.1 NOTE: The conversion constant (132) was derived from practical laboratory ambient conditions and considerations.

References

1. J.F. Brown Jr., "Quality Control Testing of Aluminum Anodes: T-7L-2 Task Group Progress Report," CORROSION/84, paper no. 346 (Houston, TX: NACE, 1984).
2. ANSI/NACE SP0115/ISO 15589-2 (Modified) (latest revision), "Petroleum, petrochemical and natural gas industries – Cathodic protection of pipeline transportation systems – Part 2: Offshore pipelines" (Houston, TX: NACE).
3. Military Specification MIL-DTL-18001 (latest revision), "Anodes, Sacrificial Zinc Alloy" (Philadelphia, PA: Department of Defense Single Stock Point [DODSSP]).(3)
4. ASTM B418 (latest revision), "Standard Specification for Cast and Wrought Galvanic Zinc Anodes" (West Conshohocken, PA: ASTM).
5. Military Specification MIL-DTL-24779 (latest revision), "Anodes, Sacrificial, Aluminum Alloy," (Philadelphia, PA: Department of Defense Single Stock Point [DODSSP]).
6. ASTM D1141 (latest revision), "Standard Practice for the Preparation of Substitute Ocean Water" (West Conshohocken, PA: ASTM).
7. ASTM G1 (latest revision), "Standard Practice for Preparing, Cleaning, and Evaluating Corrosion Test Specimens" (West Conshohocken, PA: ASTM).
8. ASTM D1193 (latest revision), "Standard Specification for Reagent Water" (West Conshohocken, PA: ASTM).

Bibliography

ASTM G3 (latest revision). "Standard Practice for Conventions Applicable to Electrochemical Measurements in Corrosion Testing." West Conshohocken, PA: ASTM.

ASTM G16 (latest revision). "Standard Guide for Applying Statistics to Analysis of Corrosion Data." West Conshohocken, PA: ASTM.

ASTM G31 (latest revision). "Standard Practice for Laboratory Immersion Corrosion Testing of Metals." West Conshohocken, PA: ASTM.

THIS PAGE IS INTENTIONALLY LEFT BLANK

THIS PAGE IS INTENTIONALLY LEFT BLANK



NACE TM0190-2017
Item #21221

ISBN 1-57590-060-2
NACE International